

DOOR SWITCH

DS 013



- > Tool-free adjustable switch positioning
- > Strain relief, suitable for range of cable diameters

- > High switching capacity
- > Suitable for lamp LED 025 and other devices

The door switch monitors the position of cabinet doors and is available in three versions. For example, it can be used for switching a light when opening a door (NC), or to activate a fan when closing a door (NO). The version with change-over contact (CO) can be used as a normally closed and/or normally open contact. The wide mechanical adjustment range of the door switch DS 013 offers versatile mounting: the housing is adjustable within a 1-3/8" (35 mm) range, while the screw flange with a slotted hole offers an additional 13/16" (21 mm). The travel of the switch itself is another 5/16" (8 mm).



TECHNICAL DATA

Max. switching capacity	10 A resistive / 1.5 A inductive @ AC 250 V
Service life	VDE: > 10,000 cycles UL: > 6,000 cycles
Connection	4-pole clamp with strain relief, clamping torque 0.5 Nm max.
Housing	plastic according to UL 94V-0, grey/black
Mounting	M5 screws (not included)
Mounting position	variable
Operating / Storage temperature	-4 to +185 °F (-20 to +85 °C)
Operating / Storage humidity	max. 90 % RH (non-condensing)
Dimensions	3.4 x 2.5 x 1.2" (87 x 64 x 30 mm)
Weight	approx. 1.8 oz. (50 g)
Protection type	IP20
Approvals	VDE, EAC; UL intended

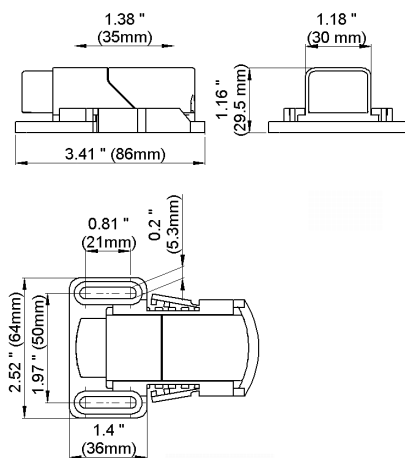

Wiring diagrams

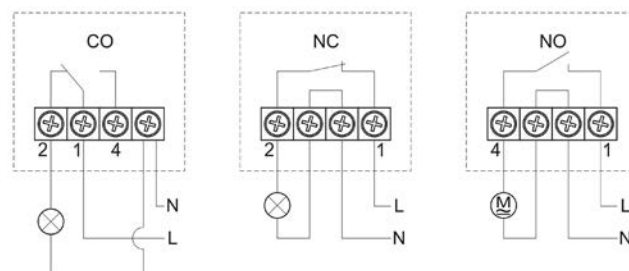

Part No.	Model	Suitable wire
01350.0-00	change-over (CO)	Round cable, stranded wire (with wire end ferrule) AWG 18 to 17 (0.75 mm ² to 1 mm ²)
01351.0-00	normally closed (NC)	Round cable, stranded wire (with wire end ferrule) AWG 18 to 16 (0.75 mm ² to 1.5 mm ²)
01352.0-00	normally open (NO)	Round cable, stranded wire (with wire end ferrule) AWG 18 to 16 (0.75 mm ² to 1.5 mm ²)